

SHEETAL ENTERPRISES

**GROUND FLOOR,SURVEY NO 223/1, DHEDHAL VASNA ROAD,NR, RAMDEVPIR MANDIR,
DHEDHAL,TAL.BAVLA,AHMEDABAD GUJARAT, 382220.
Mo.: +91 9374021441 E-mail: bhavesh126@gmail.com**

ULTRASONIC GENERATOR

User Manual

01. Foreword and Overview
02. Basic Information
03. Environment Requirements
04. Packing List
05. Interface Definition
07. Screens and Parameters
08. Most Frequently Used Setup Process for the Welding
Application
09. Errors and Possible Causes
10. About After-Sales Service

* About the version of User Manual

New product models are being constantly improved. We will continuously update the equipment hardware and software to meet a wide range of ultrasonic generator requirements. The existing version of User Manual will be rewritten or revised to introduce new or modified functions. The manual is subject to change without further notice.

1.1 Safety Requirements and Warnings

This section describes the meaning of safety precaution symbols and signs in the manual, and provides general safety precautions for the ultrasonic generator.

Pay special attention to the following signs, which will frequently appear in this manual:



Cautions

It identifies possible hazards, provides tips, and reminds users of key information or the easily overlooked information to ensure correct use of the product.



Warnings

It warns users of possible dangers and possible damage to the equipment. Failure to comply with the warning information may cause personal injury or equipment damage to different degrees.



Cautions

Use the ultrasonic generator in strict compliance with the specified method.

Take the following precautions when using the ultrasonic generator:

- User Manual describes the correct method for using the ultrasonic generator. Strictly follow the instructions in the manual.
- Use **a power socket with a ground terminal** to prevent electric shock, which is very important.
- Cut off the power supply before maintaining or repairing the ultrasonic generator. Do not dismantle the ultrasonic generator without prior approval of the Company. Otherwise, all warranties will be voided.
- In some special cases, the ultrasonic generator will produce tens of thousands of volts in some places. **Do not open the shell without authorization.**
- Periodically check the emergency stop button of the ultrasonic generator to ensure **that the button always functions properly.**
- Strictly comply with the relevant technical data of the ultrasonic generator. In particular, configure the rated parameters of the power supply and the operating environment of the system in full accordance with relevant regulations.
- Only trained operators who have fully read and understood this manual can operate the equipment.

Before installing or debugging the equipment, read this manual carefully to better use it. Failure to follow these instructions may result in damage to the transducer, horn, or mold.

2. Basic Information

Smart fan control: The fan starts running when the ultrasonic generator is working, and stops running when the ultrasonic generator stops working for 10 seconds to avoid drawing in too much dust.

Power limit: To enable the ultrasonic generator to work continuously at about 2000 W, the actual power threshold of the ultrasonic generator is 1200W

Working mode: Automatic mode: It is the long wave generating mode, suitable for cleaning, cutting, and non-woven fabric welding.

Welding machine mode: Delay time;
Welding time;
Holding time (curing time).

Voltage: 198 -242 VAC (50/60 Hz). When the AC input is 110 V, the output will be much weaker and must be adjusted. If the output is directly used, the ultrasonic generator can only be used for cutting.

Dimension: 384 mm x 240 mm x 110 mm

Weight: 7 KG

Color: Light grey

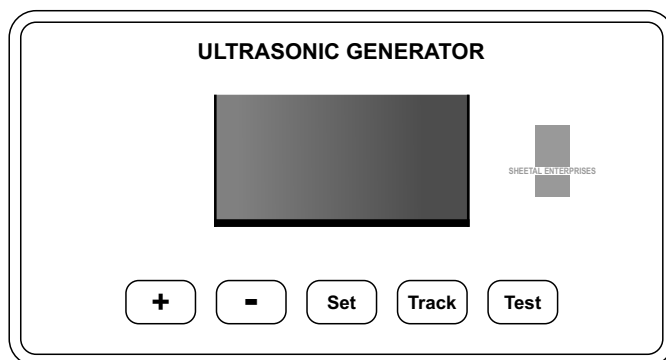

Automatic frequency tracking: The system automatically tracks the resonant frequency of the welding head, and compensates for detuning caused by heat and other reasons.

Digital frequency control: The operating frequency is digitally controlled by the microcontroller.

Digital amplitude setting: With this feature, you can set the accurate amplitude according to application requirements, which provides a larger scope and repeatability of settings compared to analog systems.

Wide adjustment range of amplitude: continuously adjustable within the range of 20%-100%, which is different from traditional generators that are difficult to work at low amplitude.

High-speed microcontroller: It uses the 32-bit ARM processor for control.

1 millisecond control and sampling interval: The ultrasonic generator samples and controls the welding process 1000 times per second.

LED and button panel: Stable and reliable.

Oblique startup: The ultrasonic energy supply and welding head are started at the most suitable ascent speed to reduce the electromechanical pressure of the system.

Diagnosis at startup: The main components of the system are tested during startup.

Comprehensive protection: including system over power consumption,

- Inverter tube overcurrent,
- Inverter tube drive undervoltage,
- Load overvoltage,
- Load frequency out-of-range,
- Overtemperature,

And overcurrent of an external device (such as the solenoid valve).

3. Environment Requirements

Whenever possible, use the ultrasonic generator in an environment that meets the following conditions, which will extend the service life of the ultrasonic generator:

Environmental Factor	Applicable Range
Operating/use temperature	0°C to +55°C
Storage/transportation temperature	-25°C to +70°C
Relative humidity	30% to 90%, without condensation



Warnings

To ensure good ventilation of the ultrasonic generator, do not cover the vent of the generator. It is strictly prohibited to use the generator in a poor environment such as an environment with corrosive gas. The air drawn in will flow through the internal circuit module. Therefore, using this generator in an environment with corrosive gas may greatly reduce the service life of the generator.

4. Packing List

Item	Quantity	Item	Quantity
Electric box of the ultrasonic generator	1	User Manual	1
1.5-meter power cable	1	DB9 connector set	1
2-pin aviation plug	1		

When unpacking the equipment, check as follows:

- Check against the packing list for missing accessories.
- Check the appearance for obvious damage.
- Connect the equipment to the power supply, and check whether the equipment runs normally.
- User Manual may be sent as a PDF file.



Warnings

The ultrasonic generator contains precision components and structures, and is sensitive to static electricity. If it is dropped or impacted during transportation, the generator's circuit may be damaged.

5. Interface Definition

DB9 interface

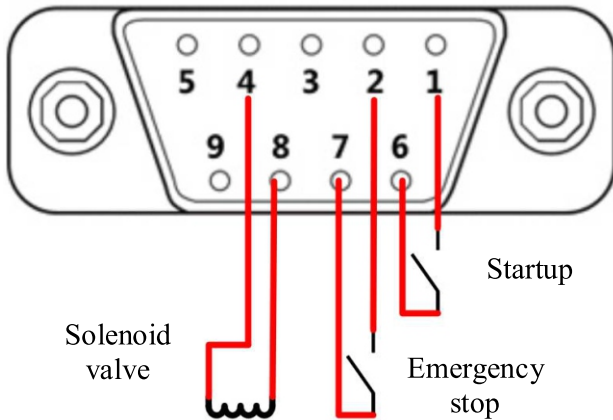

DB9 interface

1.6	Sonic ON/OFF
2.7	Emergency stop
4.8	Solenoid valve

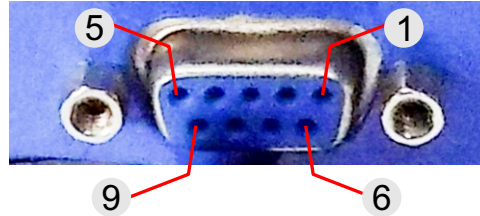

The DB9 connector set is delivered with the ultrasonic generator, and is easy to use.

1, 6	Input	When the two pins are connected, the ultrasonic generator is started. A typical application is that the two pins are connected to a normally-open micro switch or self-locking switch.
2, 7	Input	When the two pins are connected, emergency stop is triggered. A typical application is that the two pins are connected to a normally-open micro switch or self-locking switch.
4, 8	Output	24 V output voltage. The two pins are connected to a solenoid valve to control the movement of the cylinder so as to lift or lower the welding head.

Wherein, pins 6, 7, 8, and 9 are ground, and therefore pins 6, 7, and 8 can share a cable.

Ultrasonic output aviation plug



1	+, connected to the positive end of the transducer.
2	-, connected to the negative end of the transducer, and to the ground cable and chassis.

Power input connector

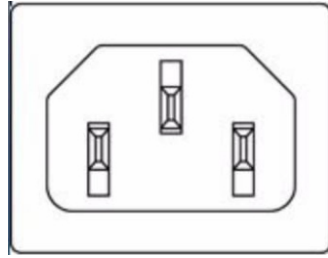

○ Cautions

The power plug must be inserted into a socket with a grounding terminal. The adaptable power range of the ultrasonic generator is 1200W VAC±10%@50/60 Hz.

The minimum core diameter of the power cable is 1.5 mm².

Fuse: 250 V, 15 A



○ Cautions

When designing and manufacturing ultrasonic generators, we've fully considered various safety factors. Refitting or modifying the system may affect the safety of the equipment during operation. Therefore, keep the following issues in mind when refitting or modifying equipment:

- *Before using components provided by other manufacturers to modify this ultrasonic welding system, contact us to determine whether these components are suitable for the modification.*
- *If the customer makes such modifications to the ultrasonic generator without the permission of the Company, all the manufacturer's warranties will be automatically voided.*

6.1 Setup Screen

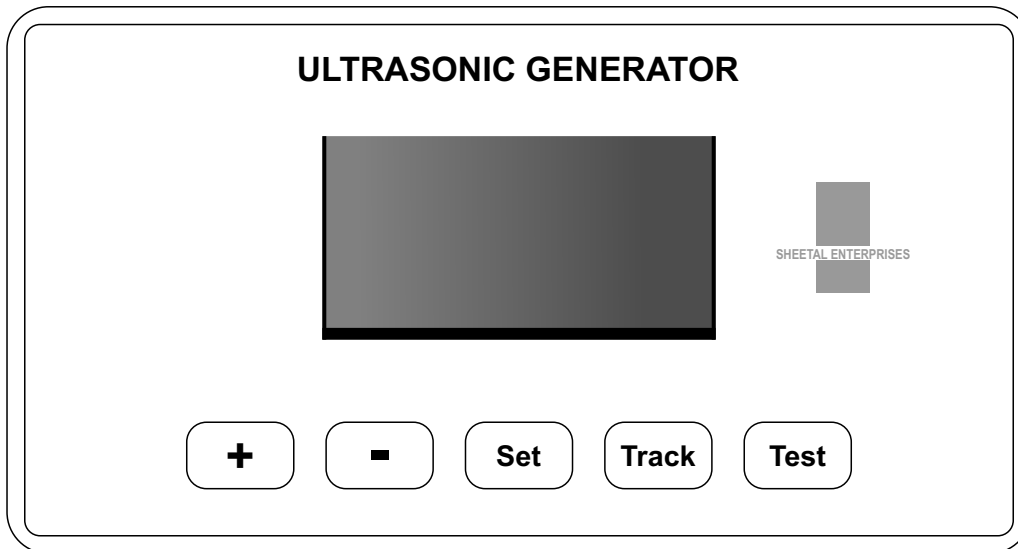

Buttons:

+: Increase the value or setting.

-: Decrease the value or setting.

Test/Enter: It is the ultrasonic wave test and input confirmation combo key. When you press and hold the Test/Enter button for more than 0.8 seconds, the ultrasonic wave test is started. This function is used for no-load mold test.

When you shortly press the Test/Enter button, the system enters the setting state or the setting is confirmed.

Mode: This button is used to select the display mode of the digital display. In normal display mode, if the original state is the Amp display state, you can press the Mode button once to enter the KHz display state; press it again to enter the Time/Plc display state; press again to enter the power display state; press again to return to the Amp display state.

AFT: This button activates the one-key frequency tracking function. When you shortly press this button, the ultrasonic generator automatically tracks the resonant frequency of the mold or the transducer (vibrator).

Indicators:

Amp: When the Amp indicator is on, the current is displayed as X.X amperes on the digital display. If the mold is too small and you press the ultrasonic wave test button, the current may be displayed as 0.0 A, which is normal.

KHz: When the KHz indicator is on, the frequency is displayed as XX.XX KHz on the digital display. This is the working frequency of the mold.

Time/Plc: When the Time/Plc indicator is on, the current working mode of the ultrasonic generator is shown on the digital display. If PLC is displayed, the working mode of the ultrasonic generator is the automatic mode, and the energy generating time of the ultrasonic generator can only be controlled by the external PLC.

If X.XX is displayed and the Delay indicator is on, the working mode of the ultrasonic generator is the plastic welding machine mode, and the ultrasonic wave generating time of the ultrasonic generator is the time pre-configured in the system.

Power: When the Power indicator is on, the amplitude percentage is shown on the digital display. The amplitude percentage can be set from 20% to 100%.

AFT: When you press the AFT button, the ultrasonic generator enters the one-key frequency tracking mode, and the AFT indicator is on. After frequency tracking is completed, the AFT indicator goes off.

Delay: When the Delay and Time/Plc indicators are on at the same time, the digital display shows the delayed ultrasonic wave generating time in plastic welding machine mode.

Welding: When the Welding and Time/Plc indicators are on at the same time, the digital display shows the ultrasonic wave generating time in plastic welding machine mode.

Holding: When the Holding and Time/Plc indicators are on at the same time, the digital display shows the holding time in plastic welding machine mode.

Warning: When the Warning indicator is on, the digital display shows the error code, such as E-01 and E-02.

Working: When the Working indicator is on, the digital display stays in its original state, indicating that the ultrasonic generator is generating the ultrasonic wave.

LED indicator bar: indicates that the amplitude of the ultrasonic generator is set from 20% to 80%, and accordingly one to eight indicators will be on.

6.2 Automatic Mode (Long Wave Generating Mode or Continuous Working Mode)

Press and hold the Test/Enter button on the panel of ultrasonic generator, turn on the power switch, and enter the automatic mode (PLC). On the mode switch interface of the plastic welding machine, you can switch the control mode of the ultrasonic generator by pressing the +/- button.

When PLC is shown on the digital display, the ultrasonic generator works in automatic mode.

When X.XX is displayed and the Delay indicator is on, the ultrasonic generator works in the plastic welding machine mode.

After selecting the working mode, wait for more than 2 seconds, and turn off the power switch. After the electricity of the equipment is fully discharged, restart it and the equipment can be used normally. (Alternatively, after turning off the power switch, press and hold the Test/Enter button to accelerate the discharge process of the equipment.)



Warnings

When you select the automatic mode, the interface provides the current working status prompt, and the Working indicator is on. When the running state is displayed, the sonic wave is being output. At this time, be cautious. If the equipment is carrying a cutting knife mold, avoid touching the tip of the knife.



Warnings

In continuous working mode (the welding time exceeding 5s), ensure that the equipment runs at a lower power. It is recommended that the power is less than 1/3 of the rated power. For example, for a 2000 W ultrasonic generator, the power should not exceed 666 W when the equipment runs continuously. The purpose is to prevent rapid heating, and extend the service life of the mold. The continuous output power can be appropriately increased when the heat dissipation condition is enhanced.

6.3. Welding Machine Mode (Parameter Settings)

1. Press the Mode button to change the mode shown on the digital display to the Time/Plc mode. The Delay and Time/Plc indicators are on.
2. Press the Test/Enter button to enter the delay time setting mode. When the digital display and the Delay indicator blink, press the +/- button to adjust the delay time.

3. Press the Mode button again to enter the welding time setting mode. When the digital display and the Welding indicator blink, press the +/- button to adjust the welding time.
4. Press the Mode button again to enter the holding time setting mode. When the digital display and the Holding indicator blink, press the +/- button to adjust the holding time.
5. After all parameters are set, press the Test/Enter button to confirm the settings and exit the parameter setting mode. Then, the digital display stops blinking.

6.4 Adjusting the Ultrasonic Amplitude

1. If you want to adjust the ultrasonic output amplitude, press the Mode button in the normal mode, set the digital display to the POWER display mode. The Power indicator is on.
2. Press the Test/Enter button to enter the amplitude percentage setting mode. At this time, the digital display blinks.
3. Shortly press the +/- button to set the output amplitude to a value between 20% and 100%.
4. Press the Test/Enter button to confirm the amplitude setting. The system exits the setting mode.

Ultrasonic wave test: The maximum amplitude in the ultrasonic wave test is 40% of the total amplitude, even if you set the amplitude to a value above 40%. If you want to have output amplitude above 40%, use the external startup mode. The purpose is to protect the mold to a certain extent and to prevent irreversible damage caused by the direct large-amplitude drive when the mold has an exception (for example, the mold is not reliably locked).

Cautions

Pressing the emergency stop switch at any time can enable the system to immediately raise the welding head, stop the ultrasonic wave, terminate a welding process, and return to the standby state.

6.5 Parameter Description

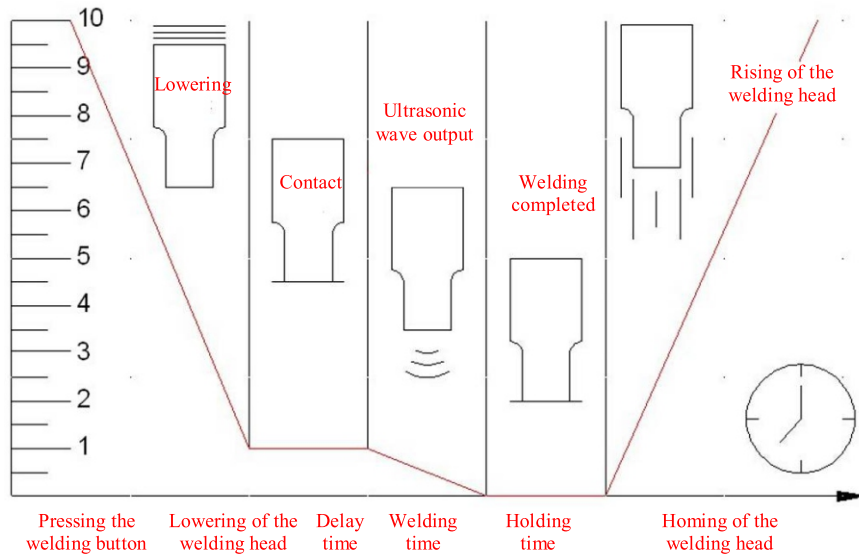

Delay time: The time from when the button is pressed to trigger welding to when the welding head is about to press against the welding workpiece. It corresponds to the time between stage 1 and stage 2 shown in the figure. The delay time is associated with the cylinder stroke and the descent speed. If you are not sure about the setting, set the delay time to a relatively large value, and then decrease the value according to the situation, for example, 0.8s. The parameter ranges from 0s to 9.99s.

Welding time: The time from when the welding head presses against the welding surface and starts to generate ultrasonic waves for welding to when the welding is completed and the ultrasonic generator stops. It corresponds to the time consumed at stage 3 shown in the figure. This value is more or less directly related to the power, air pressure, welding area, and welding depth. The parameter ranges from 0s to 9.99s.

Holding time (also called curing time or cooling time): After generation of ultrasonic wave stops at stage 4, the welding head needs to press against the product for a period of time to stick the welding workpiece tightly and cool them down. This period of time is the curing time. It corresponds to the time consumed at stage 4 in the figure. The curing time is not essential. To make the welding time as short as possible and improve efficiency, this parameter can be set to a minimum of 0.5s in most cases, depending on the welding effect. The parameter ranges from 0s to 9.99s.

7. Most Frequently Used Setup Process for the Welding Application

Select the welding machine mode for startup.

1. Start the system, wait until the system checks the operating frequency, and obtain the operating frequency.
2. Set the amplitude to 60%, and press the button to start the ultrasonic wave test. Check whether the current is within 1 A, whether the power is within 500 W, and whether the sound is the crisp sound generated at the rated frequency of the product model. If the related value is out of range, check whether the mold or the transducer is abnormal, and whether the mold is not tightened or cracks.
3. Set the delay time to 0.5s. The value is determined by the time when the welding head starts to move to when the welding head is in contact with the welding workpiece, and can be adjusted appropriately.
4. Set the welding time to 0.5s. The value is determined by the welding material, welding area, and amplitude. You can first set this parameter to a reasonable value, and then adjust it according to the results.
5. Set the holding time to 0.5s. The value is determined by the curing time of the welding material and the welding melting degree. It is recommended that you set this parameter to a large value and then decrease it to a satisfying value to accelerate the process speed.
6. Carry out trial welding, and constantly adjust the amplitude, delay time, welding time, curing time, air pressure of the rack, and mold position based on the welding results until you obtain a satisfying result.

8. Errors and Possible Causes

SN.	Error Code	Error Information
1	E-01	Communication failure between the display board and the MCU
2	E-02	Overcurrent alarm
3	E-03	Load overvoltage alarm
4	E-04	Power tube overtemperature alarm
5	E-05	Load error alarm
6	E-06	Frequency error alarm

8.1 E-01 Communication Failure Between the Display Board and the MCU

The MCU communicates with the digital display board through the RS485 port. If communication fails, this error is reported.

- After the equipment is completed powered off (LED indicators are off), restart the equipment.
- Check whether the SATA cable between the MCU board and the digital display board inside the electric box is disconnected or is not inserted in place.
- Contact us.

8.2 E-02 Overcurrent Alarm

The system detects that the load current exceeds the internally-set protection current.

If this error occurs, try to:

- Check whether the load is too large, and reduce the load. For example, reduce the cylinder air pressure and reduce the load.
- Check whether the generator and the mold are normal.
- Increase the delay time so that the product can be pressed properly before the ultrasonic wave is generated.
- Manual search the frequency again.
- If no ultrasonic wave is output, check whether the load line is short circuited.

8.3 E-03 Load Overvoltage

If this protection is triggered, the transducer has withstood a high voltage, and the equipment is likely to be damaged if it continues to work.

If this error occurs, try to:

- Decrease the amplitude to reduce the driving voltage.
- Reduce the load. For example, reduce the size of the mold or the air pressure in the plastic welding machine mode.
- Replace the horn with one that has a variable ratio below 1:2. This method is recommended. The traditional horn with a variable ratio of 1:3 is more suitable for the traditional self-excited ultrasonic wave.
- Re-search the resonance frequency.
- Check other possible causes, for example, whether the mains voltage is abnormal, and whether the transducer chip is normal.

8.4 E-04 Overtemperature Alarm

While working, the system will continuously monitor the temperature of the generator power inverter part to ensure that it can prevent further temperature rise and equipment damage in time when the temperature exceeds the limit. The design has fully considered temperature generation and heat dissipation, and this protection is not triggered under normal circumstances.

If this error occurs, try to:

- Improve the operating environment, increase the heat dissipation space, or provide external heat dissipation.
- Check whether the vent is blocked and whether the fan is damaged.
- Wait a few minutes until the temperature drops, and then restart the equipment to continue working.

8.5 E-05 Load Error (IGBT Overcurrent Protection)

If this protection is triggered, the total power consumption of the equipment is extremely large due to some reasons, and has exceeded twice the rated power in a short time. Therefore, you must handle this error with great caution.

If this error occurs, try to:

- Check whether the frequency is correct.
- Check whether the mold is damaged. Disassemble the mold or replace it with a good mold and check again.
- Check whether the load is short-circuited. For example, check the short circuit whether there is a short circuit at the load connection line and connector, or whether the withstand voltage is too low and therefore triggers short-circuit overcurrent protection.

- Check whether the excessive power consumption is caused by other problems.

8.6 E-06 Frequency Error

If the protection is triggered, the frequency has been out of lock or the frequency of the triplet of the transducer and horn mold has exceeded the preset range (for example, the preset range is 35.40 KHz to 34.20 KHz for the 35 KHz product model), and the correct working frequency of the microcontroller cannot be found after its frequency is adjusted to its limit.

If this error occurs, try to:

- Whether a load is connected to the mold during the frequency search process. The device searches for the resonance frequency with a very low amplitude. If the load is connected (such as the frequency is searched in water), the drive capacity is not enough to drive the load to obtain the correct feedback. Search the frequency without load.
- Manually search the frequency again.
- Check whether the welding head cracks, is not locked, is slipped, or gets dirty.
- Check whether the direct connection line between the generator and the load is disconnected or broken.
- Check whether the contact surface of the welding head and the horn is smooth and flat. Replace the welding head with a good one. After confirming that the equipment works normally, check whether the resonance frequency of the welding head is within the range accepted by the equipment. For example, the acceptable range is 34.20 KHz to 35.40 KHz for the 35 KHz product model.

9. About After-Sales Service

A one-year warranty service is provided for the product. If the product fails to work properly due to a quality problem within one year, please contact us. Note that the product appearance is not covered by the warranty. We will fix the problem for you as soon as possible to help you resume production.

9.1 Disclaimers

- The warranty terms do not apply to:
Any product that has been misused, not used in accordance with the instructions, improperly maintained, accidentally or incorrectly installed by the user, or altered by the user;
- Any product that is exposed to harsh environments, repaired incorrectly, repaired without authorization by using methods or materials that are not approved by the Company;
- Any product that uses accessories (such as the horn, transducer, and welding head) that are not supplied by the Company;
- Product damages caused by force majeure, such as natural disasters.

9.2 Warranty Terms

- Within the warranty period, if the product has any quality problem that leads to abnormal production, we will repair the product at no additional costs to you.
- For any parts replaced during the warranty period, the warranty period of new parts is the remaining warranty period of the replaced original parts.
- Any parts replaced after the warranty period will have a 3-month warranty.

Call us if you have any doubt about warranty issues. Contact the salesperson who sold the product according to the contact information on the cover.

(Working hours: 8:00-12:00 and 13:30-17:30 from Monday to Saturday)

- Please collect the following information before requesting for the warranty service: your company name, address, product model, purchase time, your company's contact person and contact information.
- Read this manual carefully before contacting us, and confirm that no solution is provided in the manual or the solution is not feasible.